



Migration Guide for Numonyx™ Advanced+ Boot Block Flash Memory (C3) to Numonyx™ Industry Standard Boot Block Flash Memory (M28W)

Application Note - 915

November 2008

INFORMATION IN THIS DOCUMENT IS PROVIDED IN CONNECTION WITH NUMONYX™ PRODUCTS. NO LICENSE, EXPRESS OR IMPLIED, BY ESTOPPEL OR OTHERWISE, TO ANY INTELLECTUAL PROPERTY RIGHTS IS GRANTED BY THIS DOCUMENT. EXCEPT AS PROVIDED IN NUMONYX'S TERMS AND CONDITIONS OF SALE FOR SUCH PRODUCTS, NUMONYX ASSUMES NO LIABILITY WHATSOEVER, AND NUMONYX DISCLAIMS ANY EXPRESS OR IMPLIED WARRANTY, RELATING TO SALE AND/OR USE OF NUMONYX PRODUCTS INCLUDING LIABILITY OR WARRANTIES RELATING TO FITNESS FOR A PARTICULAR PURPOSE, MERCHANTABILITY, OR INFRINGEMENT OF ANY PATENT, COPYRIGHT OR OTHER INTELLECTUAL PROPERTY RIGHT. Numonyx products are not intended for use in medical, life saving, life sustaining, critical control or safety systems, or in nuclear facility applications.

Numonyx B.V. may make changes to specifications and product descriptions at any time, without notice.

Numonyx B.V. may have patents or pending patent applications, trademarks, copyrights, or other intellectual property rights that relate to the presented subject matter. The furnishing of documents and other materials and information does not provide any license, express or implied, by estoppel or otherwise, to any such patents, trademarks, copyrights, or other intellectual property rights.

Designers must not rely on the absence or characteristics of any features or instructions marked "reserved" or "undefined." Numonyx reserves these for future definition and shall have no responsibility whatsoever for conflicts or incompatibilities arising from future changes to them.

Contact your local Numonyx sales office or your distributor to obtain the latest specifications and before placing your product order.

Copies of documents which have an order number and are referenced in this document, or other Numonyx literature may be obtained by visiting the Numonyx website at <http://www.numonyx.com>.

Numonyx, the Numonyx logo, and StrataFlash are trademarks or registered trademarks of Numonyx B.V. or its subsidiaries in other countries.

*Other names and brands may be claimed as the property of others.

Copyright © 2008, Numonyx, B.V., All Rights Reserved.

Contents

1.0	Introduction	5
2.0	Device Overview	5
2.1	Numonyx™ Advanced+ Boot Block Flash Memory (C3)	5
2.2	Numonyx™ Industry Standard Boot Block Flash Memory (M28W)	5
2.3	C3 vs. M28W Feature Comparison	5
3.0	Ballout/Pinout and Signal Descriptions	6
3.1	Easy BGA Ballout	6
3.2	TSOP Pinout	7
3.3	VF/ TF BGA Ballout	9
3.4	Signal Descriptions	10
4.0	Package Information	11
5.0	Hardware Design Considerations	13
5.1	DC Specification Comparison	16
5.2	Erase and Program Timings	17
5.3	Device Capacitance	18
6.0	Software Design Considerations	19
6.1	Device Commands	20
6.2	CFI Differences	21
7.0	Summary	21
A	Additional Information	21

Revision History

Date	Revision	Description
November 2008	01	Initial release

1.0 Introduction

This document is written for customers who need to migrate from the Numonyx™ Advanced+ Boot Block Flash Memory (C3) 130nm device to the Numonyx™ Industry Standard Boot Block Flash Memory (M28W). It includes key hardware and software differences between these two products.

This document was written based on information available at the time. Any changes in specifications to the devices since may not be reflected in this document. Refer to the appropriate datasheet or sales personnel for the most current information before finalizing any design.

2.0 Device Overview

The following sections provide a brief overview of the Numonyx Advanced+ Boot Block Flash Memory (C3) and the Numonyx Industry Standard Boot Block Flash Memory (M28W).

2.1 Numonyx™ Advanced+ Boot Block Flash Memory (C3)

The C3 device is available in 8-Mbit, 16-Mbit and 32-Mbit densities. It includes Flexible block locking which allows any block to be independently locked or unlocked and Numonyx™ Flash Data Integrator (Numonyx FDI) software. C3 products are available in 48-lead TSOP, 48-ball VF BGA and 64-ball Easy BGA.

2.2 Numonyx™ Industry Standard Boot Block Flash Memory (M28W)

The M28W device is available in 16-Mbit, 32-Mbit and 64-Mbit densities. M28W can be erased electrically at block level and programmed in-system on a word-by-word basis. Features include an instant, individual block locking scheme that allows any block to be locked or unlocked with no latency, enabling instant code and data protection. M28W products are available in 48-lead TSOP, 48-ball TF BGA, 64-ball TBGA.

2.3 C3 vs. M28W Feature Comparison

Table 1: C3 vs. M28W Comparison

Feature	C3	M28W
TSOP	yes	yes
Easy BGA	yes	No
BGA	48 Ball VF BGA	48 Ball TF BGA
Initial Access Time	70 ns	70 ns
Densities	8-, 16-, 32-Mbit	16-, 32-, 64-Mbit
Protection Register	128 bit	128 bit
V _{CC}	2.7 V - 3.6 V	2.7 V - 3.6 V
V _{CCQ}	1.65 V - 2.5 V 2.7 V - 3.6 V 1.8 V - 2.5 V	2.7 V - 3.6 V
V _{PP}	3 V or 12 V	3 V or 12 V
Bus width	x16	x16

Table 1: C3 vs. M28W Comparison

Feature	C3	M28W
Flex lock	yes	yes
Temperature	-40°C to +85°C	-40°C to +85°C
Program Word	12 μ s	10 μ s
Erase	Main block - 1 s Param block - 0.5 s	Main block - 1 s Param block - 0.4 s
Block Size	Main - 32 Kword Param - 4 Kword	Main - 32 Kword Param - 4 Kword
Program Suspend	yes	yes
Erase Suspend	yes	yes
CFI Compatible	yes	yes

3.0 Ballout/Pinout and Signal Descriptions

3.1 Easy BGA Ballout

No Migration path for this ballout. Please contact your local Numonyx rep for further details.

3.2 TSOP Pinout

The 48-lead TSOP pinout is available and compatible for both C3 and M28W in a 12 mm x 20 mm package. The TSOP lead pitch is 0.5 mm. The difference between C3 and M28W symbol conventions is given in section 5.1. The C3 TSOP pinout is shown below.

Figure 1: 48-Lead TSOP Pinout -C3

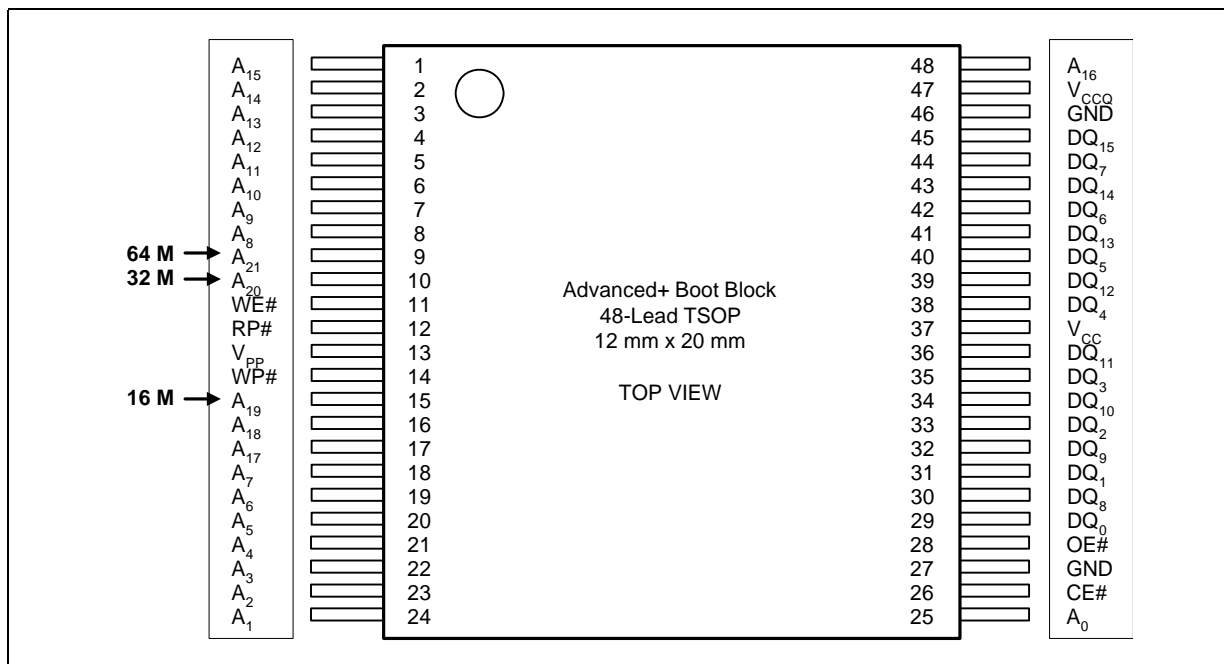

Notes:

1. A19 is valid on 16-Mbit densities and above.
2. A20 is valid on 32-Mbit densities and above.
3. A21 is valid on 64-Mbit density.

†

Figure 2: 48-Lead TSOP Pinout -M28W

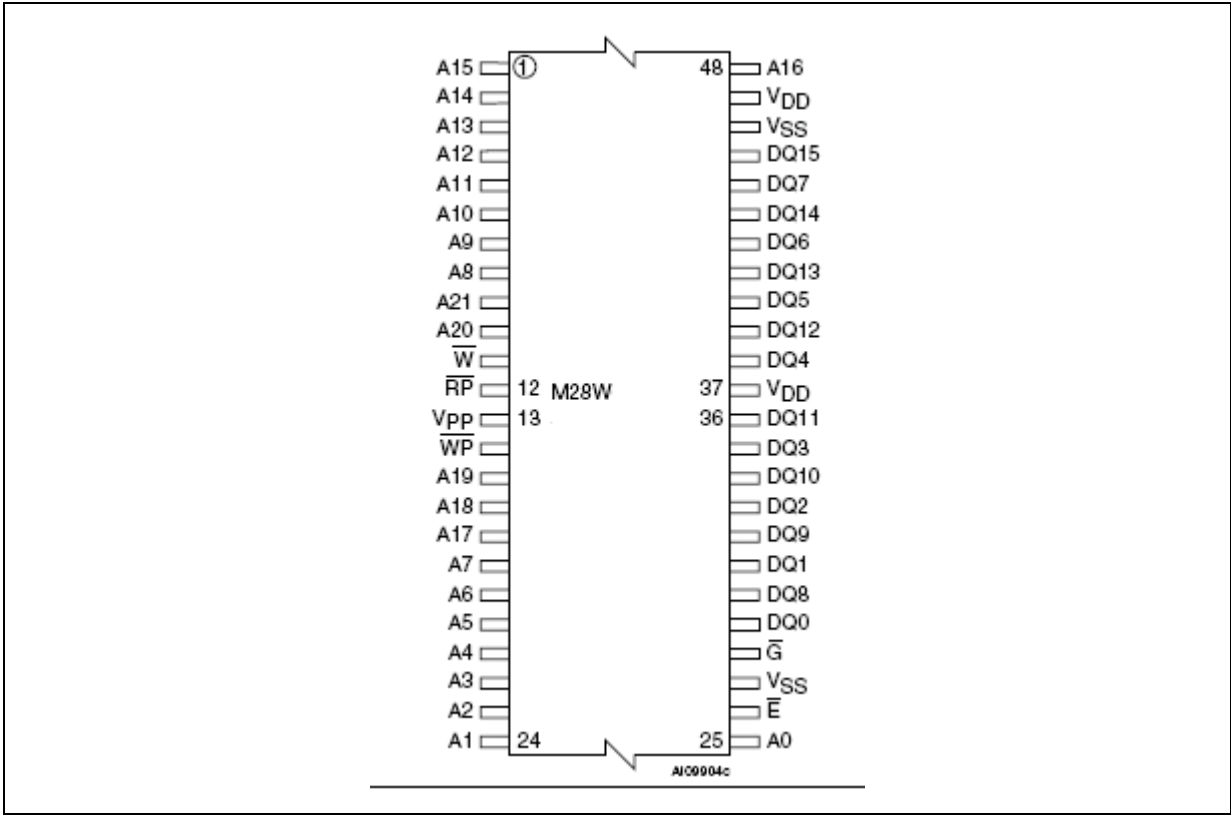

- Notes:**
1. A19 is valid on 16-Mbit densities and above.
 2. A20 is valid on 32-Mbit densities and above.
 3. A21 is valid on 64-Mbit density.

3.3 VF/ TF BGA Ballout

C3 is in the VF BGA package and M28W is in the TF BGA package. The ballout and pitch is the same for both but the package size is different. The difference between C3 and M28W symbol conventions is given in section 5.1.

Figure 3: VF BGA Package - C3

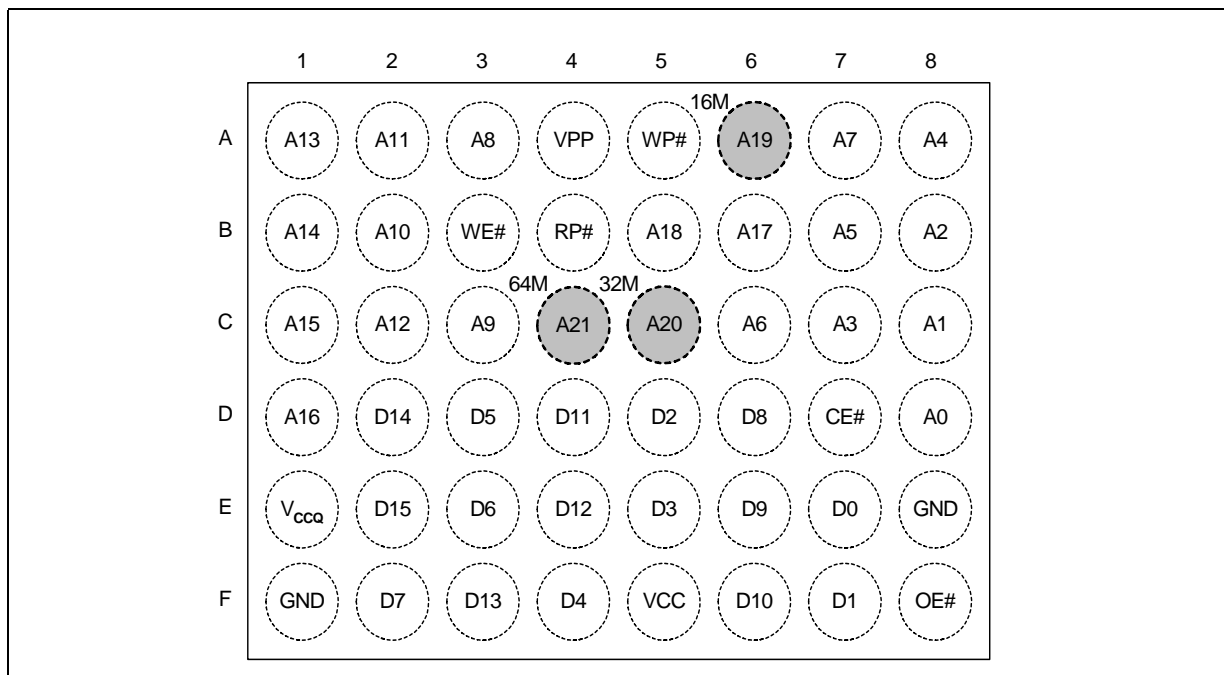

Notes:

1. A19 is valid on 16-Mbit densities and above.
2. A20 is valid on 32-Mbit densities and above.

3. A21 is valid on 64-Mbit density.

Figure 4: TF BGA Package - M28W

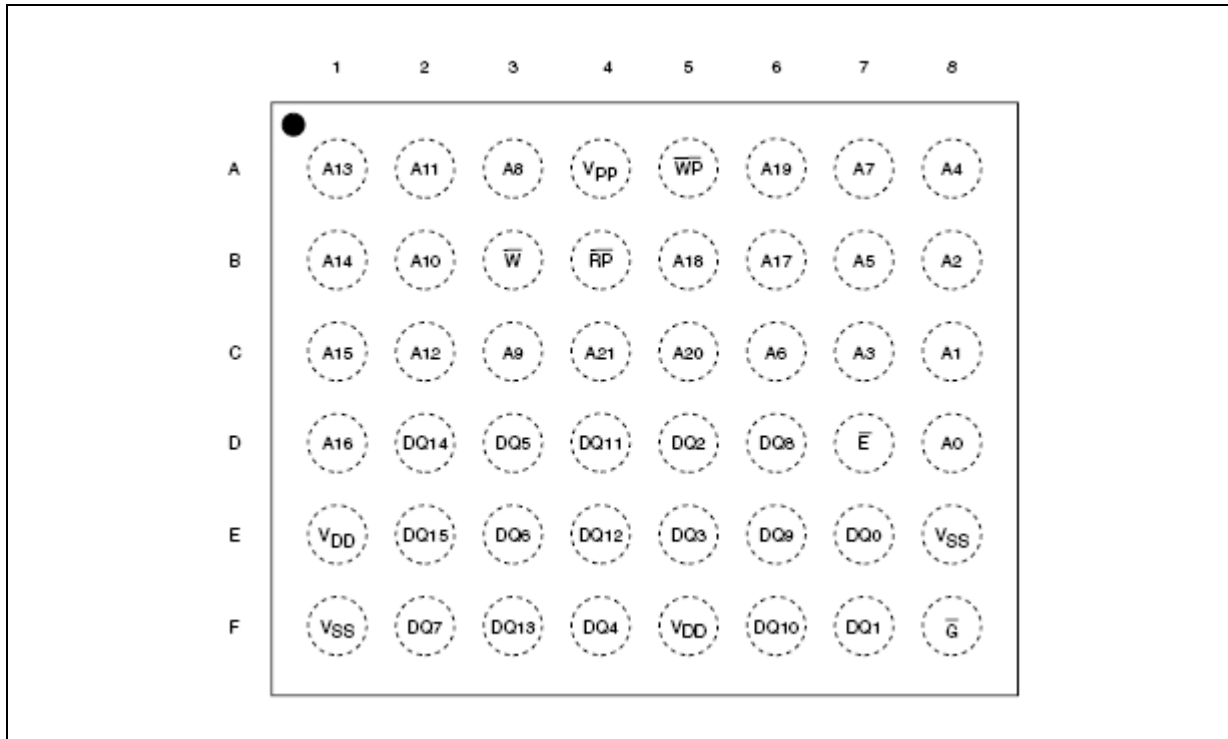

3.4 Signal Descriptions

The below table gives the difference in the naming of the symbols between the C3 and M28W device.

Table 2: Signal Symbol Differences

Product		Description	Direction
C3	M28W		
A[MAX:0]	A0-A21	Address Inputs	Inputs
DQ[15:0]	DQ0-DQ15	Data Input/Output	Input/Output
CE#	\bar{E}	Chip Enable	Input
OE#	\bar{G}	Output Enable	Input
WE#	\bar{W}	Write Enable	Input
RP#	$\bar{R}\bar{P}$	Reset	Input
WP#	$\bar{W}\bar{P}$	Write Protect	Input
V _{CC}	V _{DD}	Power Supply	Power Supply
V _{PP}	V _{PP}	Program/Erase Power Supply	Power Supply
GND	V _{SS}	Ground	--
DU		Don't Use	--
NC	NC	Not Connected Internally	--

4.0 Package Information

VF BGA Package Drawing

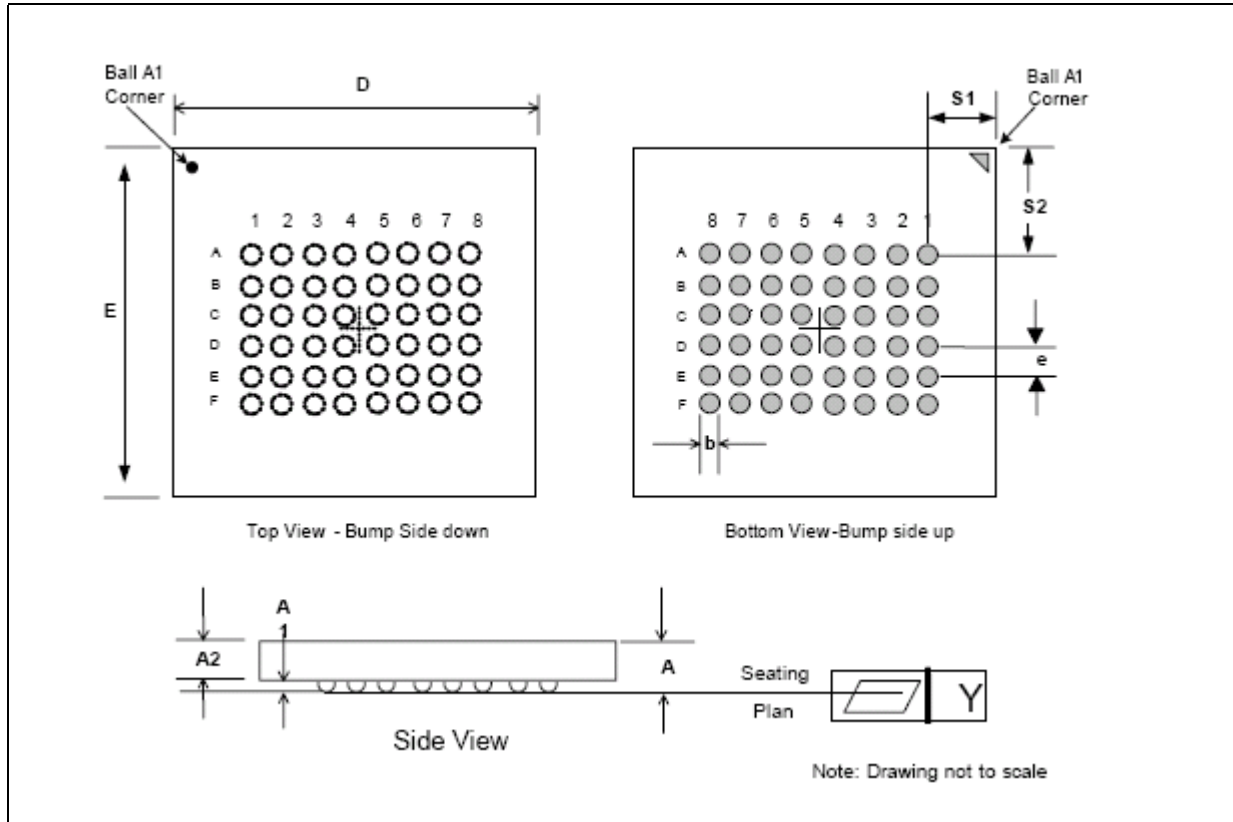

†

Figure 5: TF BGA Package Drawing

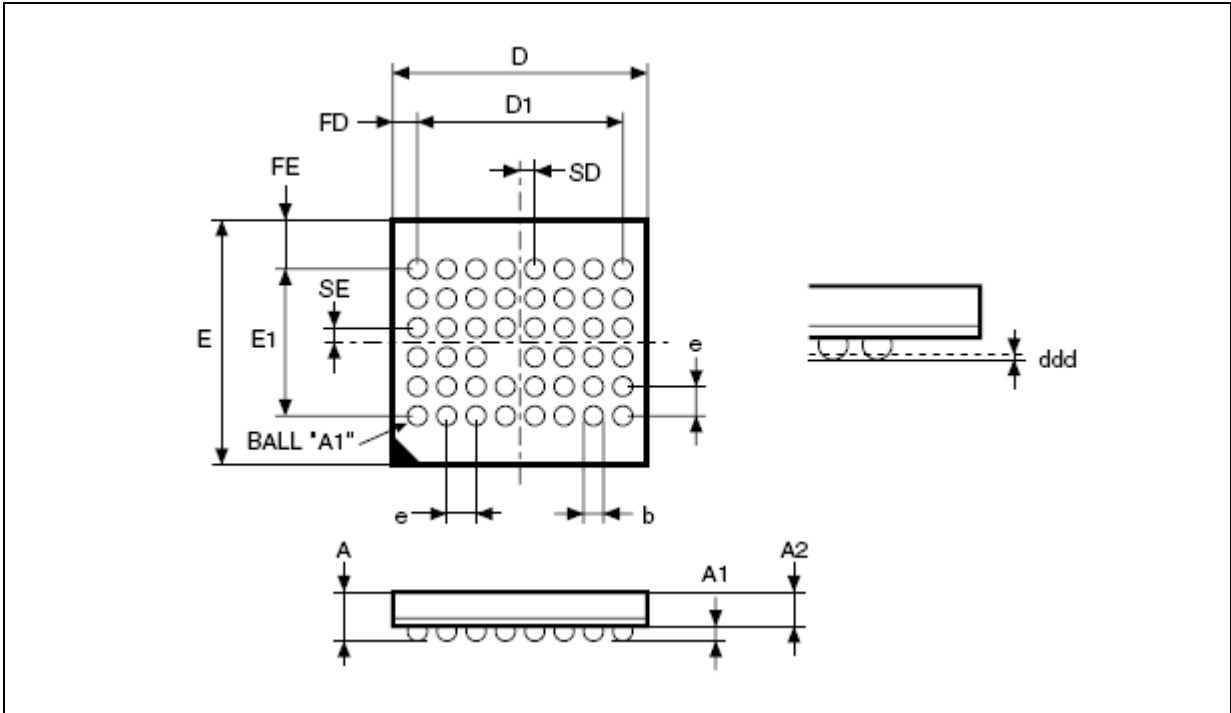

Table 3: VF BGA / TF BGA Package Dimensions

Dimension	Symbol	C3			M28W			Unit
		Min	Nom	Max	Min	Nom	Max	
Package height	A	--	--	1.00	--	--	1.200	mm
Ball Height	A1	0.15	--	--	0.200	--	--	mm
Package body thickness	A2	--	0.665	--	--	--	1.00	mm
Ball width	b	0.325	0.3	0.425	0.35	0.400	0.45	mm
Package body length (16-, 32-Mbit)	D	7.186	7.286	7.386	6.29	6.39	6.49	mm
Package body length (64-Mbit)	D	--	--	--	6.29	6.39	6.49	mm
Package body width(16-, 32-Mbit)	E	6.864	6.964	7.064	6.2	6.37	6.47	mm
Package body width(64-Mbit)		--	--	--	10.40	10.50	10.60	mm
Pitch	e	--	0.75	--	--	0.75	--	mm

5.0 Hardware Design Considerations

This section discusses hardware design considerations between C3 and M28W.

5.0.1 16-Mbit Spec Comparisons

The following read and write specification tables compare the 16-Mbit C3 device with the 16-Mbit M28W device.

Table 4: AC Read Specifications: 16-Mbit C3 and M28W

Symbol	Specification	C3	M28W	Unit
t_{AVAV}	Address Valid to Next Address Valid	70	70	ns
t_{AVQV}	Address Valid to Output Valid	70	70	ns
t_{OH} t_{AXQX}	Address Transition to Output Transition	0	0	ns
t_{OH} t_{EHQX}	Chip Enable High to Output Transition	0	0	ns
t_{EHQZ}	Chip Enable High to Output High Z	20	20	ns
t_{ELQV}	Chip Enable Low to Output Valid	70	70	ns
t_{ELQX}	Chip Enable Low to Output Transition	0	0	ns
t_{GHQX}	Output Enable High to Output Transition	0	0	ns
t_{GHQZ}	Output Enable High to Output High Z	20	20	ns
t_{GLQV}	Output Enable Low to Output Valid	20	20	ns
t_{GLQX}	Output Enable Low to Output Transition	0	0	ns
t_{PHQV}	RP# to Output Delay	150	--	ns

Table 5: AC Write Specifications: 16-Mbit C3 and M28W (Sheet 1 of 2)

Symbol	Specification	C3	M28W	Unit
t_{AVWH} t_{AVEH}	Address Valid to Write Enable High	50	45	ns
t_{DVWH} t_{DVEH}	Data Valid to WE# (CE#) Going High	40	45	ns
t_{ELWL} t_{WLEL}	CE# (WE#) Low to WE# (CE#) Going Low	0	0	ns
t_{QVVL} t_{QVVPL}	VPP Hold from Valid Output	0	0	ns
t_{QVBL} t_{QVWPL}	Write Protect Hold from Valid Output	0	0	ns
t_{VPWH} t_{VPHEH} t_{VPHWH} t_{VPHEH}	VPP Setup to WE# (CE#) Going High	200	200	ns
t_{WHAX} t_{EHAX}	Address Hold from WE# (CE#) High	0	0	ns

Table 5: AC Write Specifications: 16-Mbit C3 and M28W (Sheet 2 of 2)

Symbol	Specification	C3	M28W	Unit
t_{WHDX} t_{EHDX}	Data Hold from WE# (CE#) High	0	0	ns
t_{WHEH} t_{EHWH}	CE# (WE#) Hold Time from WE# (CE#) High	0	0	ns
t_{WHEL}	WE# High to Chip Enable Low	25	25	ns
t_{WHGL} t_{EHGL}	WE# (CE#) High to Output Enable Low	30	20	ns
t_{WHWL} t_{EHEL}	WE# (CE#) High to WE# (CE#) Low	25	25	ns
t_{WLWH} t_{ELEH}	WE# (CE#) Low to WE# (CE#) High	45	45	ns
t_{BHWL} t_{BHEH} t_{WPHWH} t_{WPHEH}	Write Protect High to WE# (CE#) High	0	45	ns
t_{PHWL} t_{PHEL}	RP# High Recovery to WE# (CE#) going Low	150	--	ns

5.0.2 32-Mbit Spec Comparisons

These following read and write specification tables compares the 32-Mbit C3 device with the 32-Mbit M28W device.

Table 6: AC Read Specifications: 32-Mbit C3 and M28W

Symbol	Specification	C3	M28W	Unit
t_{AVAV}	Address Valid to Next Address Valid	70	70	ns
t_{AVOV}	Address Valid to Output Valid	70	70	ns
t_{OH} t_{AXOQ}	Address Transition to Output Transition	0	0	ns
t_{OH} t_{EHQX}	Chip Enable high to Output Transition	0	0	ns
t_{EHQZ}	Chip Enable High to Output High Z	20	20	ns
t_{ELQV}	Chip Enable Low to Output Valid	70	70	ns
t_{ELQX}	Chip Enable Low to Output Transition	0	0	ns
t_{GHQX}	Output Enable High to Output Transition	0	0	ns
t_{GHQZ}	Output Enable High to Output High Z	20	20	ns
t_{GLOV}	Output Enable Low to Output Valid	20	20	ns
t_{GLQX}	Output Enable Low to Output Transition	0	0	ns
t_{PHQV}	RP# to Output Delay	150	--	ns

Table 7: AC Write Specifications: 32-Mbit C3 and M28W

Symbol	Specification	C3	M28W	Unit
t_{AVWH} t_{AVEH}	Address Valid to Write Enable High	50	45	ns
t_{DVWH} t_{DVEH}	Data Valid to WE# (CE#) Going High	40	45	ns
t_{ELWL} t_{WLEL}	CE# (WE#) Low to WE# (CE#) Going Low	0	0	ns
t_{QVVL} t_{QVVPL}	VPP Hold from Valid Output	0	0	ns
t_{QVBL} t_{QVWPL}	Write Protect Hold from Valid Output	0	0	ns
t_{VPWH} t_{VPHEH} t_{VPHWH} t_{VPHEH}	VPP Setup to WE# (CE#) Going High	200	200	ns
t_{WHAX} t_{EHAX}	Address Hold from WE# (CE#) High	0	0	ns
t_{WHDX} t_{EHDX}	Data Hold from WE# (CE#) High	0	0	ns
t_{WHEH} t_{EHWH}	CE# (WE#) Hold Time from WE# (CE#) High	0	0	ns
t_{WHEL}	WE# High to Chip Enable Low	25	25	ns
t_{WHGL} t_{EHGL}	WE# (CE#) High to Output Enable Low	30	20	ns
t_{WHWL} t_{EHEL}	WE# (CE#) High to WE# (CE#) Low	25	25	ns
t_{WLWH} t_{ELEH}	WE# (CE#) Low to WE# (CE#) High	45	45	ns
t_{BHWL} t_{BHEH} t_{WPHWH} t_{WPHEH}	Write Protect High to WE# (CE#) High	0	45	ns
t_{PHWL} t_{PHEL}	RP# High Recovery to WE# (CE#) going Low	150	--	ns

5.1 DC Specification Comparison

The following table compares DC specifications for the C3 device and the M28W device. Please refer the relevant datasheet for complete specs.

Note: The V_{CC} for both devices is 2.7 V to 3.6 V. The V_{CCQ} range for the M28W device is 2.7 V to 3.6 V, while the V_{CCQ} range for C3 varies as shown in the table.

Table 8: DC Characteristics: C3 and M28W

Symbol	Parameter	C3			M28W	Unit	Notes
		$V_{CCQ} = 2.7\text{ V} - 3.6\text{ V}$	$V_{CCQ} = 1.65\text{ V} - 2.5\text{ V}$	$V_{CCQ} = 1.8\text{ V} - 2.5\text{ V}$	$V_{CCQ} = 2.7\text{ V} - 3.6\text{ V}$		
I_{CCS} / I_{DD1}	Standby Current	7 (Typ) / 15 (Max)	15 (Typ) / 20 (Max)	50 (Typ) / 150m(Max)	15 (Typ) / 50m(Max)	μA	1,3
I_{CCR} / I_{DD}	Read Current	9 (Typ) / 18 (Max)	8 (Typ) / 15 (Max)	9 (Typ) / 15 (Max)	9 (Typ) / 18 (Max)	mA	2,4
V_{IL}	Input Low Voltage	Min = -0.5 Max = 0.4	Min = -0.4 Max = 0.4	Min = -0.4 Max = 0.4	Min = -0.4 Max = $V_{CC}+0.22$	V	—
V_{IH}	Input High Voltage	Min = 2.0 Max = $V_{CCQ}+0.22$	Min = $V_{CCQ}-0.4$ Max = $V_{CCQ}+0.3$	Min = $V_{CCQ}-0.4$ Max = $V_{CCQ}+0.3$	Min = $V_{CCQ}-0.4$ Max = $V_{CCQ}+0.4$	V	
V_{LKO}	Supply Voltage (Program and erase lock Voltage)	1.5 (Min)	1.5 (Min)	1.5 (Min)	2 (max)	V	

Notes:

1. C3 standby current test conditions: $V_{CC} = V_{CCMax}$; $CE\# = RP\# = V_{CCQ}$ or during program/erase /suspend; $WP\# = V_{CCQ}$ or GND.
2. C3 read current test conditions: $V_{CC} = V_{CCMax}$; $V_{CCQ} = V_{CCQMax}$; $OE\# = V_{IH}$; $CE\# = V_{IL}$; $f = 5\text{ MHz}$; $I_{OUT} = 0\text{mA}$; Inputs = V_{IL} or V_{IH}
3. M28W standby current test conditions: $\bar{E} = V_{DD} \pm 0.2\text{ V}$; $\overline{RP} = V_{DD} \pm 0.2\text{ V}$.
4. M28W read current test conditions: $\bar{E} = V_{SS}$; $G = V_{IH}$; $f = 5\text{ MHz}$.

5.2 Erase and Program Timings

Table 9: Erase and Program Timings -C3

Symbol	Parameter	V _{PP}	1.65 V–3.6 V		11.4 V–12.6 V		Unit
		Note	Typ	Max	Typ	Max	
t _{BWPS}	4-KW Parameter Block Word Program Time	1, 2, 3	0.10	0.30	0.03	0.12	s
t _{BWMB}	32-KW Main Block Word Program Time	1, 2, 3	0.8	2.4	0.24	1	s
t _{WHQV1} / t _{EHQV1}	Word Program Time for 0.13 and 0.18 Micron Product	1, 2, 3	12	200	8	185	μs
	Word Program Time for 0.25 Micron Product	1, 2, 3	22	200	8	185	μs
t _{WHQV2} / t _{EHQV2}	4-KW Parameter Block Erase Time	1, 2, 3	0.5	4	0.4	4	s
t _{WHQV3} / t _{EHQV3}	32-KW Main Block Erase Time	1, 2, 3	1	5	0.6	5	s
t _{WHRH1} / t _{EHRH1}	Program Suspend Latency	1,3	5	10	5	10	μs
t _{WHRH2} / t _{EHRH2}	Erase Suspend Latency	1,3	5	20	5	20	μs

Notes:

1. Typical values measured at T_A = +25 °C and nominal voltages.
2. Excludes external system-level overhead.
3. Sampled, but not 100% tested.

Table 10: Erase and Program Timings- M28W

Parameter	Test Conditions	M28W:			Unit
		Min	Typ	Max	
Word Program	V _{PP} = V _{DD}		10	200	μs
Double Word Program	V _{PP} = 12V ±5%		10	200	μs
Quadruple Word Program	V _{PP} = 12V ±5%		10	200	μs
Main Block Program	V _{PP} = 12V ±5%		0.16/0.08 ⁽¹⁾	5	s
	V _{PP} = V _{DD}		0.32	5	s
Parameter Block Program	V _{PP} = 12V ±5%		0.02/0.01 ⁽¹⁾	4	s
	V _{PP} = V _{DD}		0.04	4	s
Main Block Erase	V _{PP} = 12V ±5%		1	10	s
	V _{PP} = V _{DD}		1	10	s
Parameter Block Erase	V _{PP} = 12V ±5%		0.4	10	s
	V _{PP} = V _{DD}		0.4	10	s
Program/Erase Cycles (per Block)		100,000			cycles
Data Retention		20			years

Notes:

1. Typical time to program a Main or Parameter Block using the Double Word Program and the Quadruple Word Program commands respectively.

5.3 Device Capacitance

The Device Capacitance for C3 and M28W are shown below

Table 11: Device Capacitance

Symbol	Parameter	C3	M28W	Unit
C_{IN}	Input Capacitance	6 (Typ) / 8 (Max)	6 (Max)	pF
C_{OUT}	Output Capacitance	8 (Typ) / 12 (Max)	12 (Max)	pF

6.0 Software Design Considerations

The following table goes over the software differences between C3 and M28W.

Table 12: Software Differences

Feature	C3	M28W
Manufacturer ID	0x0089	0x0020
Device ID 8Mb	Top: 0x88C0 Bottom: 0x88C1	NA
Device ID 16Mb	Top: 0x88C2 Bottom: 0x88C4	Top: 0x88CE Bottom: 0x88CF
Device ID 32Mb	Top: 0x88C4 Bottom: 0x88C5	Top: 0x88BA Bottom: 0x88BB
Device ID 64Mb	--	Top: 0x8848 Bottom: 0x8849
Commands	NA	Double Word Program
	NA	Quadruple Word Program

6.1 Device Commands

The command set for the C3 and M28W devices are fully compatible. Command sets are compared here:

Table 13: Command Sets

Commands	C3	M28W
Read Array	FFh	FFh
Program Setup	40h	40h
Erase Setup	20h	20h
Erase Confirm	D0h	D0h
Program/Erase Suspend	B0h	B0h
Program/Erase resume	D0h	D0h
Read Status	70h	70h
Clear Status	50h	50h
Read Identifier	90h	90h
Lock Setup	60h	60h
Lock Block/Lock confirm	01h	01h
Lock Down	2Fh	2Fh
Protection Program Setup	C0h	C0h
Alt program Setup	10h	10h
CFI query	98h	98h

6.2 CFI Differences

During adoption of Numonyx or third party software, several differences must be taken into account. This section will show the changes.

Table 14: System Interface Information

Offset	Description	C3			M28W		
		Addr	Hex Code	Value	Addr	Hex Code	Value
1Fh	"n" such that typical single word program time-out = 2^n μ s	1F	--05	32 μ s	1F	--04	16 μ s
20h	"n" such that typical max. buffer write time-out = 2^n μ s	20	--00	NA	NA	NA	NA
20h	Typical Time-out for Double Word Program = 2^n μ s	NA	NA	NA	20h	--04	16 μ s
23h	"n" such that maximum word program time-out = 2^n times typical	23	--04	512 μ s	23	--05	512 μ s
24h	"n" such that maximum buffer write time-out = 2^n times typical	24	00	NA	NA	NA	NA
24h	Maximum time-out for Double Word Program = 2^n times typical	NA	NA	NA	24	--05	512 μ s

7.0 Summary

This Migration Guide enables customers to understand the hardware and software differences between the C3 and M28W flash memory devices. Please refer to the relevant datasheet for additional information.

Appendix A Additional Information

Order Number	Document/Tool
290645	Numonyx™ Advanced+ Boot Block Flash Memory (C3)
--	Numonyx™ Industry Standard boot Block (M28W) M28W160EC, M28W160C and M28W320FC

