

Differences between the
M29W320DB/T and the M29W320EB/T Flash Memories

Introduction

The purpose of this Application note is to highlight the differences between from the M29W320D and the M29W320E Flash memories. The M29W320D and M29W320E Flash memories are members of the family of industry standard Flash memories from Numonyx, and are suited for use in most applications. The M29W320E is a recent addition to the family and presents some new features compared to the M29W320D.

Contents

- 1 Main Features of the M29W320D and M29W320E 3**
 - 1.1 Additional features of the M29W320E 3
- 2 Comparing the M29W320D and the M29320E 4**
 - 2.1 Packages, pinout, and ballout 4
 - 2.2 Block organization 6
 - 2.2.1 M29W320D 6
 - 2.2.2 M29W320E 7
 - 2.3 Block Protect and Chip Unprotect commands 10
 - 2.3.1 M29W320D Block Protect 10
 - 2.3.2 M29W320E Block Protect 10
 - 2.4 Hardware protection 10
 - 2.4.1 Hardware protection in the M29W320D 10
 - 2.4.2 Hardware protection in the M29W320E 10
 - 2.5 Enter Extended Block command 10
 - 2.6 Exit Extended Block command 11
 - 2.7 Double Word Program command 11
 - 2.8 Quadruple Byte Program command 11
- 3 Differences in electrical parameters 13**
- 4 Conclusions 14**
- 5 Revision history 15**

1 Main Features of the M29W320D and M29W320E

The M29W320D and M29W320E are 32 Mbit (4 Mbit x8 or 2 Mbit x16) non-volatile memories that can be read, erased and reprogrammed. These operations can be performed using a single low voltage (2.7 V to 3.6 V) supply.

The M29W320D and M29W320E are available with access times of 70 ns and 90 ns in two temperature ranges:

- temperature range 6: -40 °C to 85 °C
- temperature range 1: 0 °C to 70 °C

The M29W320E and M29W320D are manufactured in a 0.11 µm process technology.

1.1 Additional features of the M29W320E

An additional feature of the M29W320E compared to the M29W320D is that it contains an extra 32 KWord (x16 mode) or 64 KByte (x8 mode) block, the Extended Block, that can be accessed using a dedicated command.

The Extended Block can be protected and so is useful for storing security information. However the protection is irreversible, once protected the protection cannot be undone.

The M29W320E has other features not available on the M29W320D, using which several adjacent Words or Bytes can be written in parallel, thus improving the programming throughput. Two Fast Program commands are provided for that purpose, the:

- Quadruple Byte Program command (available for x8 operations)
- Double Word Program command (available for x16 operations)

These programming features can be used to speed up programming mainly on third-party programmers by reducing the number of instruction cycles required for programming and by cutting by 4 the whole chip program time.

2 Comparing the M29W320D and the M29320E

This document shows the major differences between the M29W320D and the M29W320E by comparing the two memory devices in terms of package, pinout, command set, and electronic signature.

Table 1. Feature Comparison

Sales Type	M29W320D	M29W320E
Package	TSOP48 (12 x 20mm / TFBGA48 (6 x 8mm)	TSOP48 (12 x 20mm)/ TFBGA48 (6 x 8mm)
Block organization	Boot Blocks: 16/8/8/32KB Main Blocks: 64KB x 63 blocks	Boot Blocks: 8KB x 8 blocks Main Blocks: 64KB x 63 blocks
Extended Block	No	Yes: 64KB
Double Word Program	No	Yes
Protection	Boot Blocks: single block Main Blocks: single block	Boot Blocks: single block Main Blocks: – block 0 single – Blocks 1,2,3 grouped – Other main blocks grouped by 4
WP	Outermost 16KB Block	2 outermost 8KB Blocks
Device codes	22CA (Top configuration) 22CB (Bottom configuration)	2256 (Top configuration) 2257 (Bottom configuration)

2.1 Packages, pinout, and ballout

The M29W320D and M29W320E are both offered in the TSOP48 and TFBGA48 packages and are fully, pin-to-pin and ball-to-ball compatible as shown in Figure 1 and Figure 2, so that the PCB does not need modified when migrating from the M29W320D to the M29W320E. The fact that they are delivered in the same packages provides an exact drop-in solution.

Figure 1. Full TSOP48 pinout compatibility

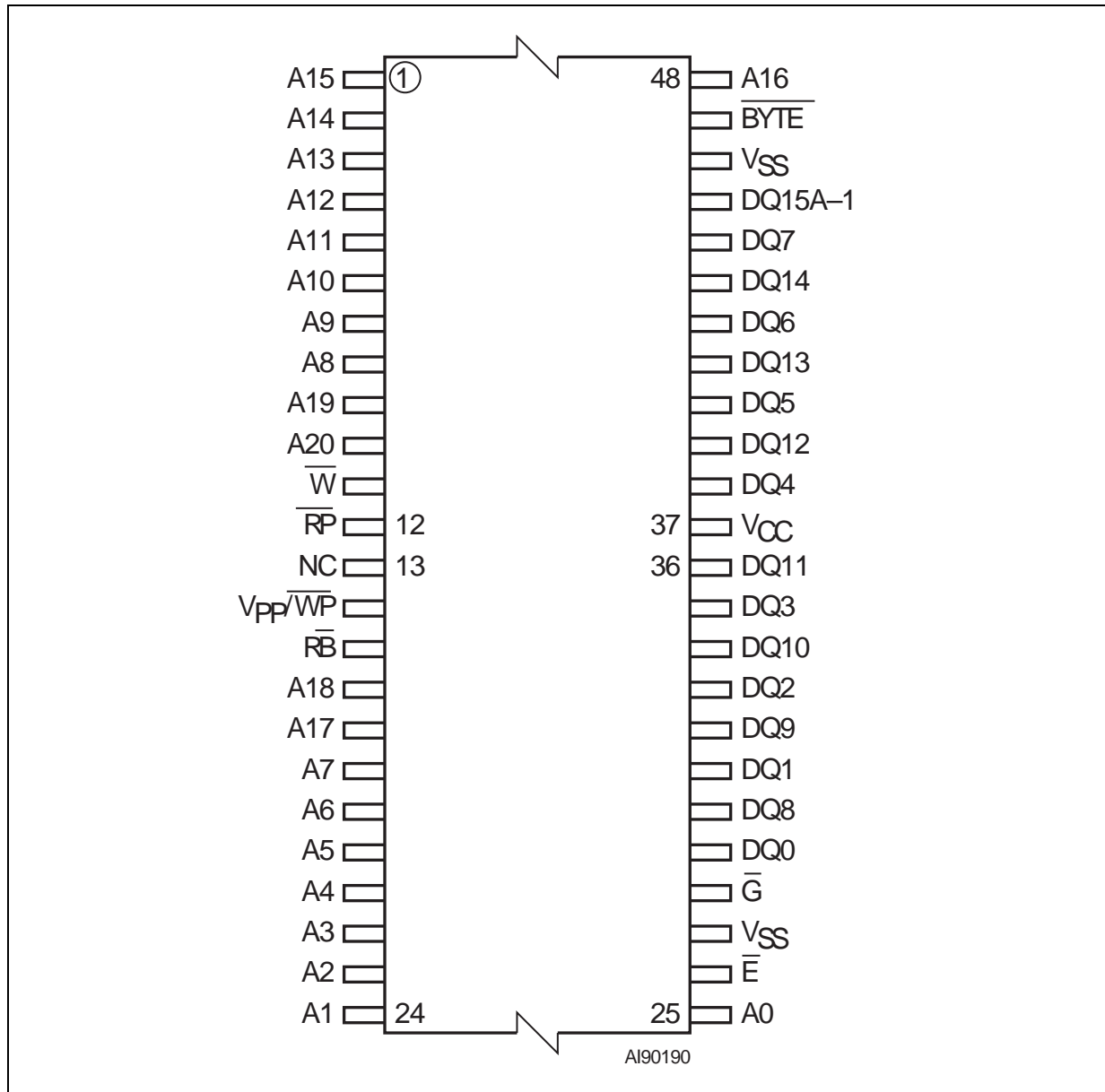
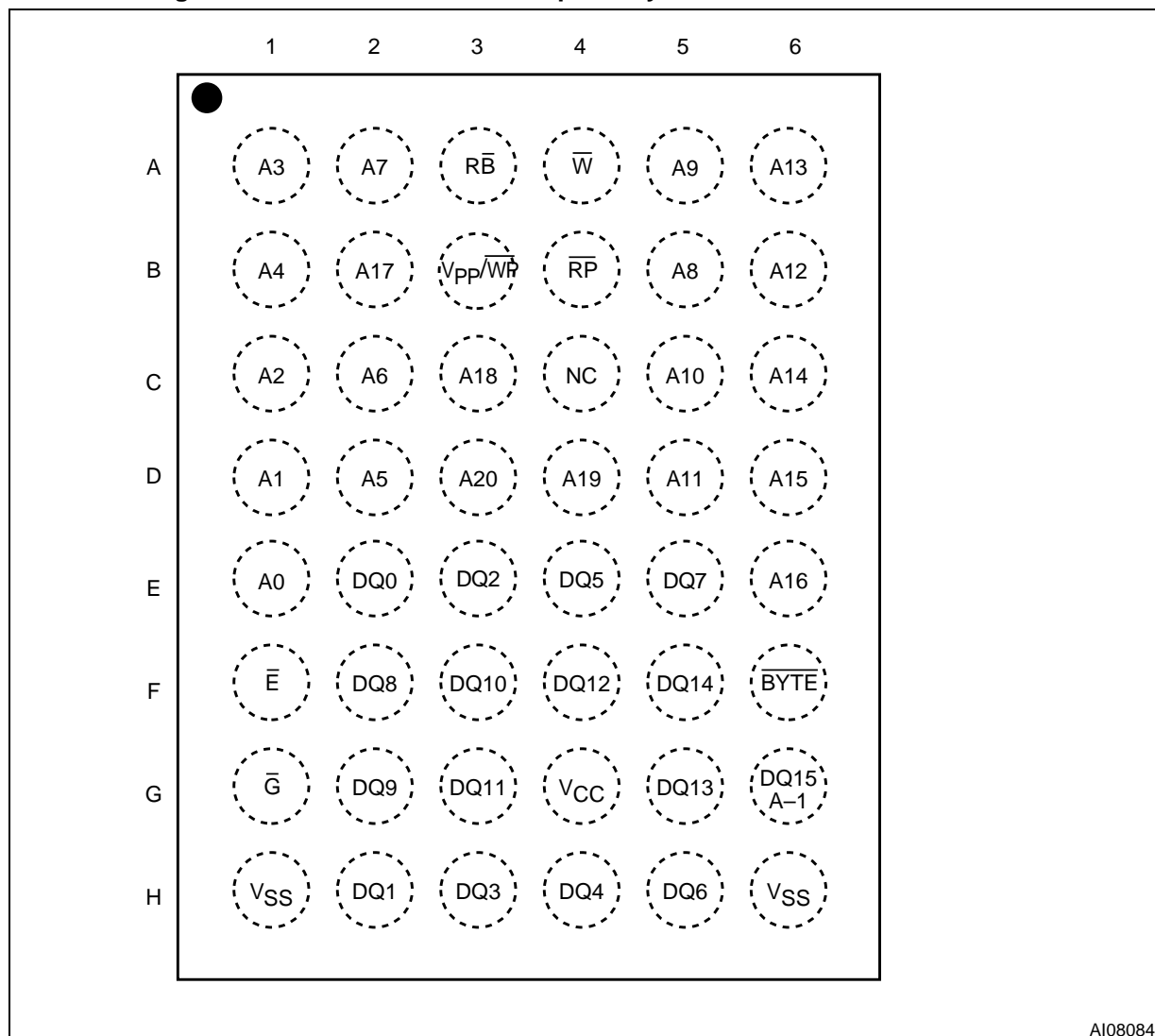

Figure 2. TFBGA48 ballout compatibility



AI08084

2.2 Block organization

The M29W320D and M29W320E both have an asymmetrical block organization as described below.

2.2.1 M29W320D

The M29W320D is organized as 63 Main Blocks of 64 KBytes plus 1 Boot Block of 16 KBytes plus 2 Parameter Blocks of 8 KBytes and 1 small Main Block of 32 KBytes. The device is available in both top (M29W320DT) and bottom (M29W320DB) boot block configurations.

2.2.2 M29W320E

The M29W320E is organized as 63 Main blocks of 64 KBytes and 8 Parameter Blocks of 8 KBytes. The device is available in both top (M29W320ET) and bottom (M29W320EB) boot configurations.

The M29W320E has a more flexible block organization in terms of Parameter Blocks with respect to the M29W320D. In terms of Main Blocks, the organization is exactly the same for both devices, which means that the application code can be stored without requiring any changes.

Figure 3. M29W320E block addresses (x8)

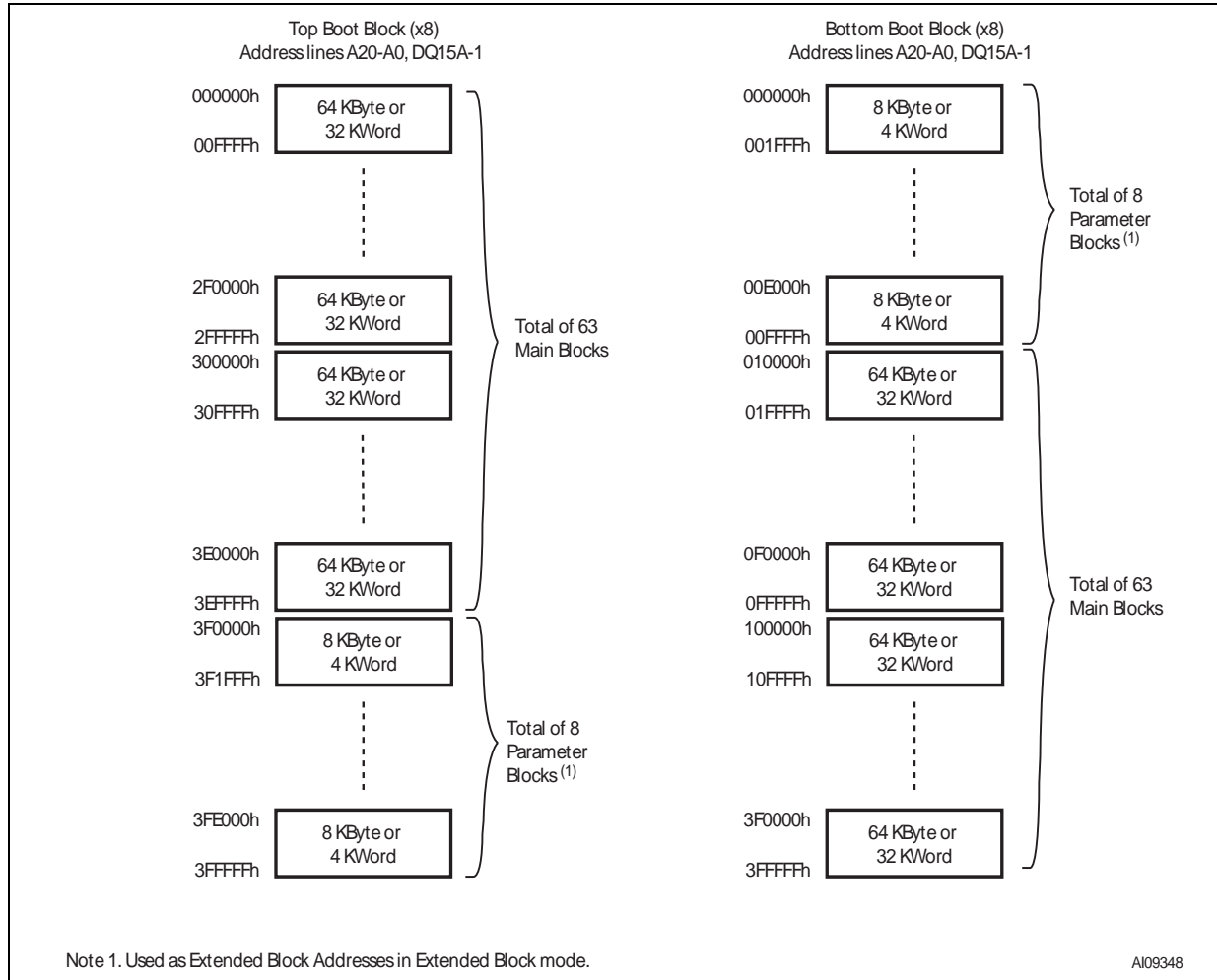

Figure 4. M29W320E block addresses (x16)

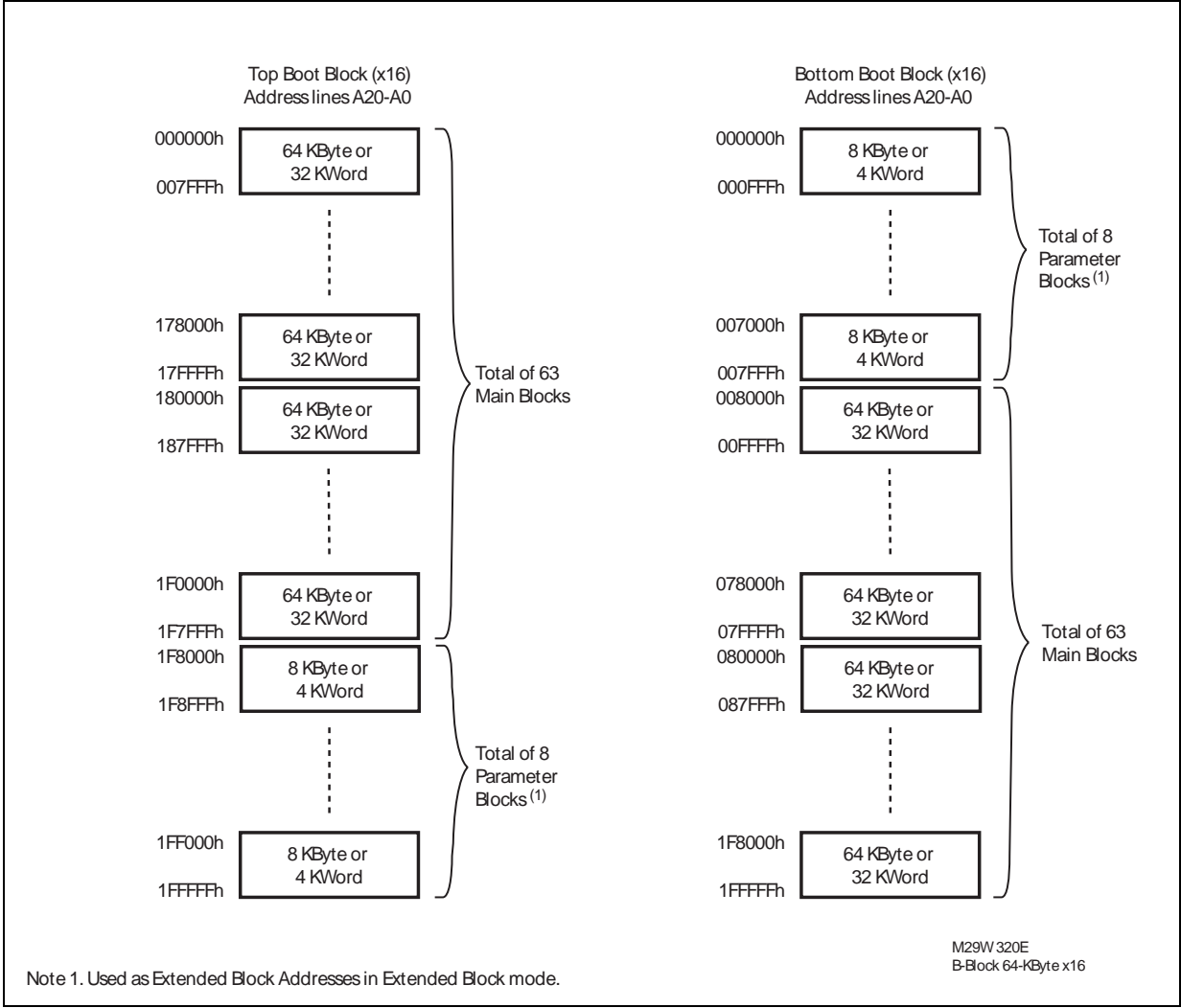

Figure 5. M29W320D block addresses (x8)

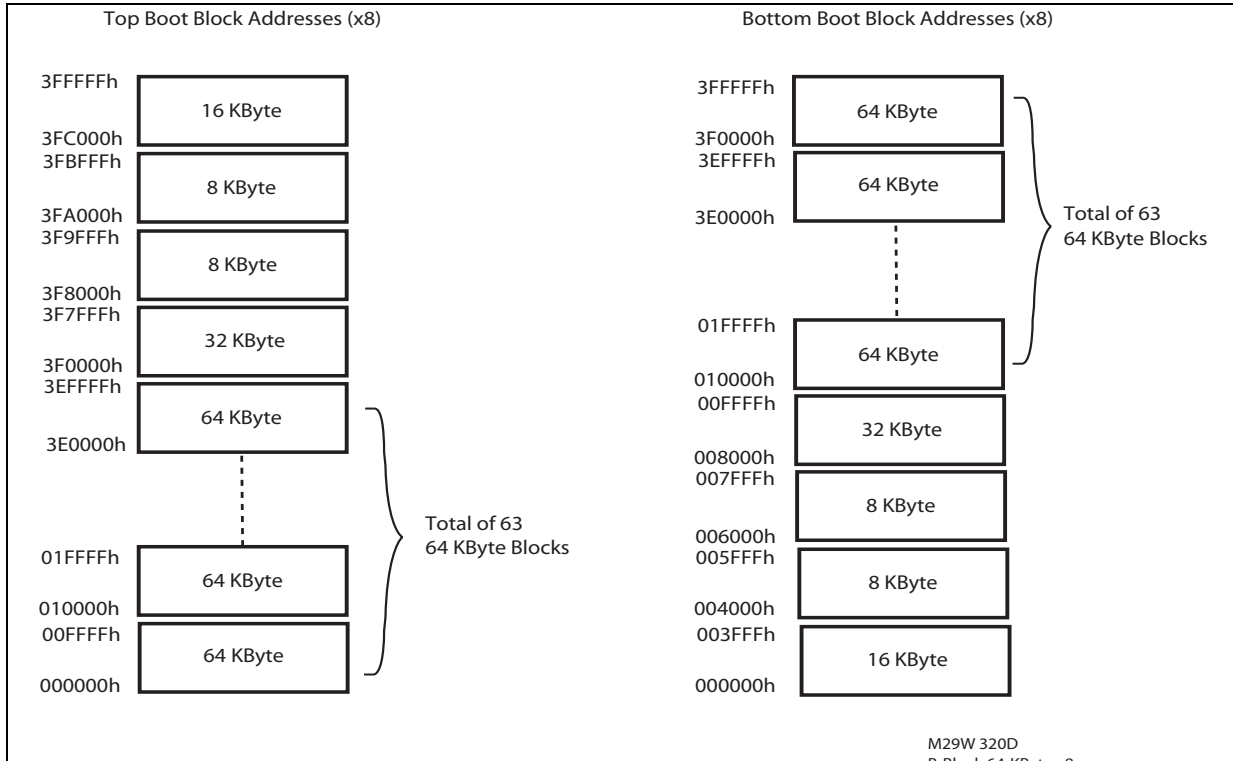
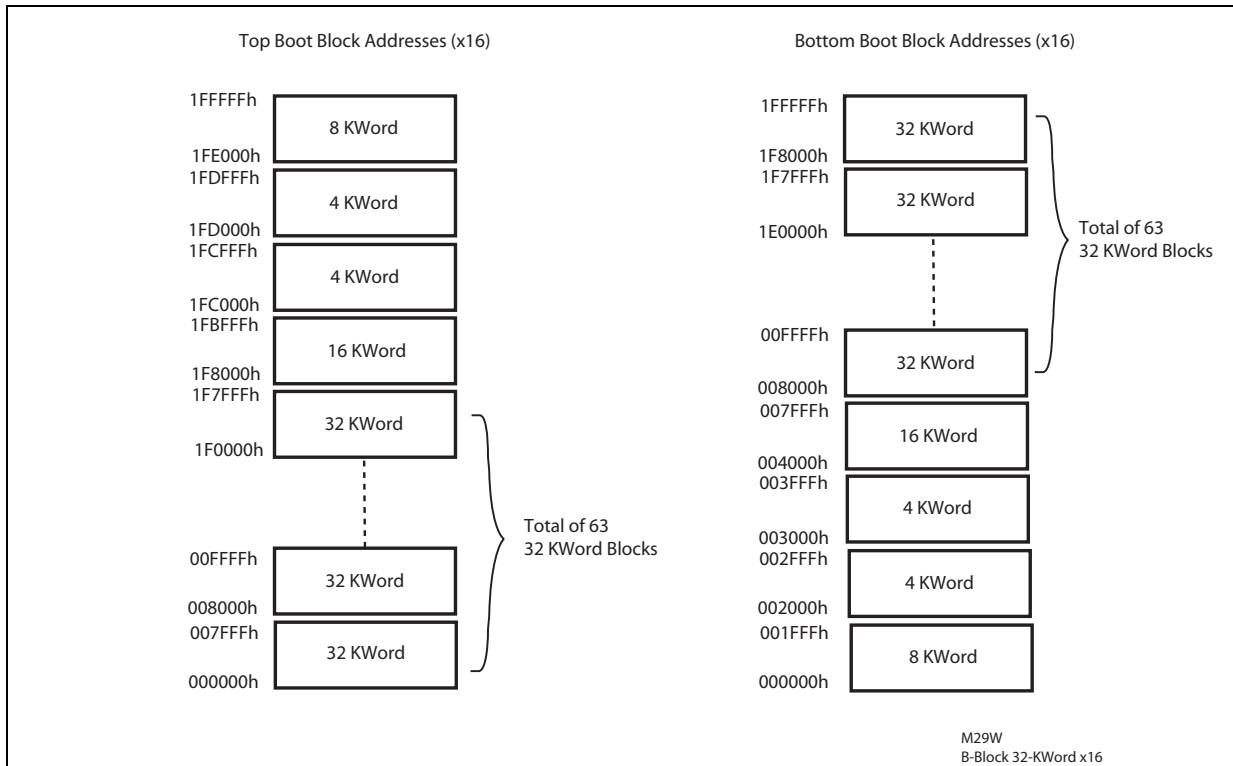

Figure 6. M29W320D block addresses (x16)



2.3 Block Protect and Chip Unprotect commands

In both the M29W320D and M29W320E, the Block Protect command allows blocks to be protected against accidental program or erase.

Using the Chip Unprotect command, the whole chip can be unprotected to allow the data inside the blocks to be changed.

2.3.1 M29W320D Block Protect

The Block Protect command can be used to separately protect each block against accidental program or erase.

2.3.2 M29W320E Block Protect

The Block Protect command can be used to protect the Main Blocks by Protection groups, except for Main Block 0 (in the Top configuration) or Main Block 70 (in the Bottom configuration), which can be protected separately. The parameters blocks can also be protected separately using the Block Protect algorithm.

See the M29W320ET/B datasheet for detailed tables of the Protection Groups for the top and bottom configurations.

2.4 Hardware protection

The M29W320D and M29W320E both feature a hardware Boot Block protection by using the VPP/Write Protect pin.

2.4.1 Hardware protection in the M29W320D

When VPP/Write Protect is Low, VIL, the 16 KByte Boot Block of the memory is protected. Program and erase operations in this block are ignored as long as VPP/Write Protect remains Low.

2.4.2 Hardware protection in the M29W320E

When VPP/Write Protect is Low, VIL, the two outermost 8 KByte Boot Blocks of the memory are protected.

As the hardware-protected boot block size is the same (one 16 KByte Boot Block in the M29W320D and two 8 KByte Boot Blocks in the M29W320E), it is not required to modify the application when migrating from the M29W320D to the M29W320E.

2.5 Enter Extended Block command

The M29W320E has an extra 64 KByte block (Extended Block) that can only be accessed using the Enter Extended Block command. Three Bus write cycles are required to issue the Extended Block command.

Once the command has been issued the device enters the Extended Block mode where all Bus Read or Program operations to the Boot Block addresses access the Extended Block. Once programmed, the Extended Block (with the same addresses as the Boot Block) can no longer be erased, and so can be treated as one-time programmable (OTP) memory.

In Extended Block mode the Boot Blocks are not accessible.

See Table 2 and Table 3 for details of how to implement the Enter Extended Block command.

2.6 Exit Extended Block command

The Exit Extended Block command is available in the M29W320E only. It is used to exit from the Extended Block mode and return the device to Read mode. Four Bus Write operations are required to issue the command.

See Table 2 and Table 3 for details of how to implement the Exit Extended Block command.

2.7 Double Word Program command

The Double Word Program command is available in the M29W320E only. It is used to write a page of two adjacent Words in parallel. The two Words must differ only for the address A0. Three bus write cycles are necessary to issue the Double Word Program command.

- The first bus cycle sets up the Double Word Program command.
- The second bus cycle latches the Address and the Data of the first Word to be written.
- The third bus cycle latches the Address and the Data of the second Word to be written and starts the Program/Erase Controller.

See Table 2 and Table 3 for details of how to implement the Double Word Program command.

2.8 Quadruple Byte Program command

The Quadruple Byte Program command is available in the M29W320E only. It is used to write a page of four adjacent Bytes in parallel. The four Bytes must differ only for addresses A0, DQ15A-1. Five bus write cycles are necessary to issue the Quadruple Byte Program command.

- The first bus cycle sets up the Quadruple Byte Program Command.
- The second bus cycle latches the Address and the Data of the first Byte to be written.
- The third bus cycle latches the Address and the Data of the second Byte to be written.
- The fourth bus cycle latches the Address and the Data of the third Byte to be written.
- The fifth bus cycle latches the Address and the Data of the fourth Byte to be written and starts the Program/Erase Controller.

See Table 2 and Table 3 for details of how to implement the Double Byte Program command.

Table 2. M29W320E commands, 16-bit mode, BYTE = VIH

Command	Length	Bus Write Operations ⁽¹⁾							
		1st		2nd		3rd		4th	
		Addr	Data	Addr	Data	Addr	Data	Addr	Data
Double Word Program	3	555	50	PA0	PD0	PA1	PD1		
Enter Extended Block	3	555	AA	2AA	55	555	88		
Exit Extended Block	4	555	AA	2AA	55	555	90	X	00

1. X Don't Care, PA Program Address, PD Program Data, BA Any address in the Block. All values in the table are in hexadecimal. The Command Interface only uses A-1, A0-A10 and DQ0-DQ7 to verify the commands; A11-A20, DQ8DQ14 and DQ15 are Don't Care. DQ15A-1 is A-1 when BYTE is VIL or DQ15 when BYTE is VIH.

Table 3. M29W320E commands, 8-bit mode, BYTE = VIL

Command	Length	Bus Write Operations ⁽¹⁾									
		1st		2nd		3rd		4th		5th	
		Add	Data	Add	Data	Add	Data	Add	Data	Add	Data
Quadruple Byte Program	5	AAA	55	PA0	PD0	PA1	PD1	PA2	PD2	PA3	PD3
Enter Extended Block	3	AAA	AA	555	55	AAA	88				
Exit Extended Block	4	AAA	AA	555	55	AAA	90	X	00		

1. X Don't Care, PA Program Address, PD Program Data, BA Any address in the Block. All values in the table are in hexadecimal. The Command Interface only uses A-1, A0-A10 and DQ0-DQ7 to verify the commands; A11-A20, DQ8DQ14 and DQ15 are Don't Care. DQ15A-1 is A-1 when BYTE is VIL or DQ15 when BYTE is VIH.

3 Differences in electrical parameters

Only two parameters differ as shown in Table 4.

Table 4. Electrical Parameters

Parameter	Symbol	Alt Symbol	Maximum Value ⁽¹⁾		Unit
			M29W320E	M29W320D	
Erase Suspend Latency Time			50	25	μs
RP Low to Read Mode (Max value)	tPLY	tREADY	50	25	μs

1. Maximum value measured at worst case conditions for both temperature and VCC.

4 Conclusions

The M29W320D and M29W320E are offered in the same TSOP48 and TFBGA48 packages and are pin-to-pin / ball-to-ball compatible. All commands of the M29W320D exist in the M29W320E, with some differences at the level of the Block Protect and Chip Unprotect commands.

The M29W320E features additional commands meant to speed up programming (Double Word Program and Quadruple Byte Program) and to gain access to or exit the Extended Block (Enter Extended Block and Exit Extended Block) which is an additional feature of the M29W320E.

The hardware block protection provided by VPP/Write Protect is also somewhat different in the M29W320D and M29W320E, but the hardware-protected memory size is the same.

5 Revision history

Table 5. Document revision history

Date	Revision	Changes
10-Apr-2006	1	Initial release.
07-Oct-2008	2	Applied Numonyx template.
14-July-2010	3	Revised TSOP pinout.

Please Read Carefully:

INFORMATION IN THIS DOCUMENT IS PROVIDED IN CONNECTION WITH NUMONYX™ PRODUCTS. NO LICENSE, EXPRESS OR IMPLIED, BY ESTOPPEL OR OTHERWISE, TO ANY INTELLECTUAL PROPERTY RIGHTS IS GRANTED BY THIS DOCUMENT. EXCEPT AS PROVIDED IN NUMONYX'S TERMS AND CONDITIONS OF SALE FOR SUCH PRODUCTS, NUMONYX ASSUMES NO LIABILITY WHATSOEVER, AND NUMONYX DISCLAIMS ANY EXPRESS OR IMPLIED WARRANTY, RELATING TO SALE AND/OR USE OF NUMONYX PRODUCTS INCLUDING LIABILITY OR WARRANTIES RELATING TO FITNESS FOR A PARTICULAR PURPOSE, MERCHANTABILITY, OR INFRINGEMENT OF ANY PATENT, COPYRIGHT OR OTHER INTELLECTUAL PROPERTY RIGHT.

Numonyx products are not intended for use in medical, life saving, life sustaining, critical control or safety systems, or in nuclear facility applications.

Numonyx may make changes to specifications and product descriptions at any time, without notice.

Numonyx, B.V. may have patents or pending patent applications, trademarks, copyrights, or other intellectual property rights that relate to the presented subject matter. The furnishing of documents and other materials and information does not provide any license, express or implied, by estoppel or otherwise, to any such patents, trademarks, copyrights, or other intellectual property rights.

Designers must not rely on the absence or characteristics of any features or instructions marked "reserved" or "undefined." Numonyx reserves these for future definition and shall have no responsibility whatsoever for conflicts or incompatibilities arising from future changes to them.

Contact your local Numonyx sales office or your distributor to obtain the latest specifications and before placing your product order.

Copies of documents which have an order number and are referenced in this document, or other Numonyx literature may be obtained by visiting Numonyx's website at <http://www.numonyx.com>.

Numonyx StrataFlash is a trademark or registered trademark of Numonyx or its subsidiaries in the United States and other countries.

*Other names and brands may be claimed as the property of others.

Copyright © 2010, Numonyx, B.V., All Rights Reserved.